

SERVO DRIVEN



HIGHLIGHTS

- ✓ Flexible, programmable pad printing
- ✓ x-y-z Servo motor
- ✓ No tools required in setup
- ✓ Touch Screen panel
- ✓ Minimal downtime
- ✓ Integrated ink residue pick-up system
- ✓ 150x600mm printing area
- ✓ OSHA approved guarding
- ✓ Manufactured in USA

ADAPTIVE SERIES

A concept for all industrial sectors with an unprecedented flexibility.

With this "Servo Driven Machine" Tampprint International Corporation presents a new generation in pad printing systems. The adaptive series provides the flexible and unique opportunity for programmable section of artwork pickup and lay down in the x and y coordinates. This allows the user to print multiple artworks in vastly different areas on a part inside a 150x600mm print area. Provided in 1-6 cliché modules, the possibilities are endless.



technologies for your future
made in germany

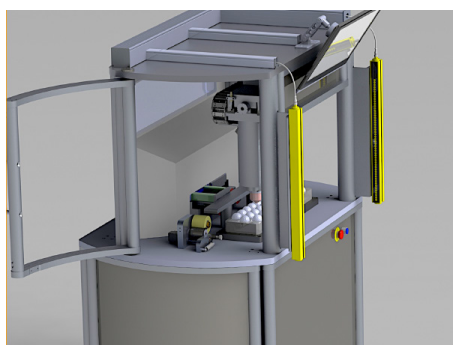

Compact Design

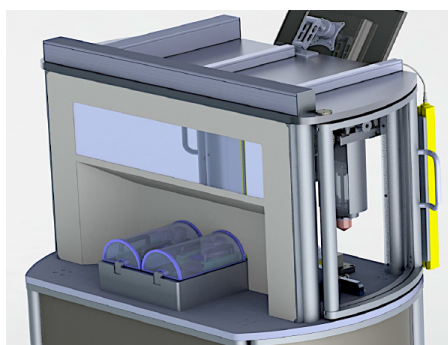

Cliché Modules

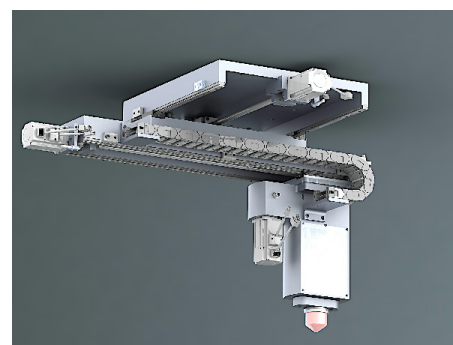

Detail: Pad Unit Servo Electrical Drive

TECHNICAL DATA

Adaptive S1		
Cycles/h	Max.	1,800
Ink/Doctoring Cup Size	ø mm	60, 90, 130
Cliché Size	mm	140 x 70 215 x 100 300 x 150
Printing Image Size	ø mm	55, 85, 120
Drive	Servo Electrical	
Width	mm	1,300
Depth	mm	1,000
Height	mm	1,800
Weight	Apx Kg	1,134



MACHINE FACTS!

- ✓ The steel frame of the “Adaptive” series provides a strong, sturdy support for this flexible system.
- ✓ Provided in 3 different cliché sizes and in multiple platforms, the “Adaptive” series provides endless printing possibilities.
- ✓ The x-y-z- Servo motor allows for many different printing levels along a 150x600mm printing area.
- ✓ The tool less, independent cliché modules allow for continuous production while still carrying out fast ink/cliché changes.
- ✓ The software allows for an infinite number of saved programs, making job setup easier than ever.
- ✓ The automatic door locks. Locked cliché compartments, and light curtains insure a safe working environment.

Tampo Canada Inc.
 1037 North Service Rd. E.
 Oakville, Ontario L6H 1A6
 Ph: 905.267.0126 Fx: 905.267.0127
 Email: mail@tampocanada.com



The reproduction of trademarks and brands used in this brochure, even if not explicitly expressed, does not justify the assumption that such names or symbols may be considered as free as defined by the Trademark Act and may therefore freely be used. The rights are the property of the respective owner.

TAMPOPRINT® products are permanently updated to keep pace with the latest technological developments. For this reason, figures and descriptions are non-binding. Our machines are manufactured based on the currently valid European Machinery Directives as well as the European product standards EN 1010 - 1 and EN 1010 - 2.

Subject to alterations! ©Copyright